

Model Number

LS-HHBC400W

LS-HHBC500W

LS-HHBC600W

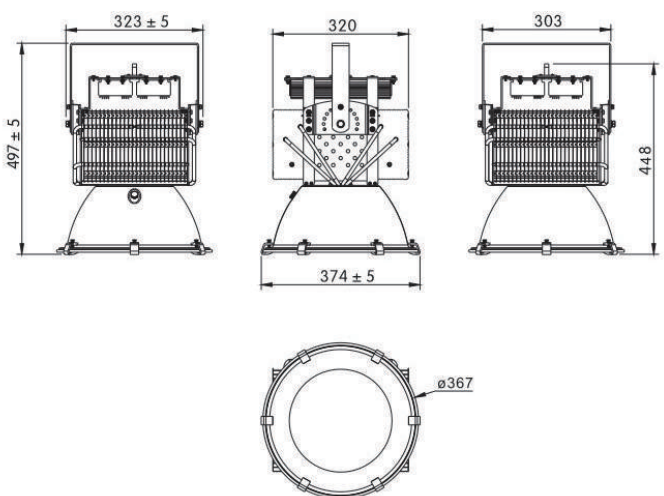

LS-HHBC400W

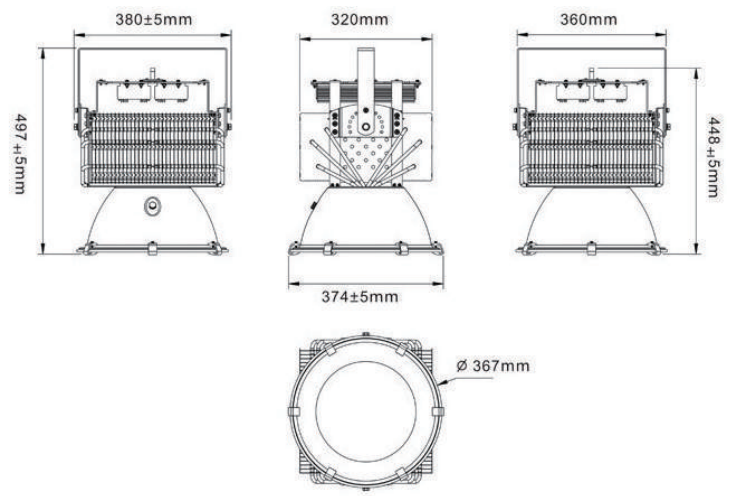

LS-HHBC500W/600W

Luminous Intensity Distribution(C)

UNIT:cd

— V 0.0DEG PLAN
— H 0.0DEG PLAN

BeamAngle(50%):85.0 Deg

BeamAngle(10%):105.0 Deg

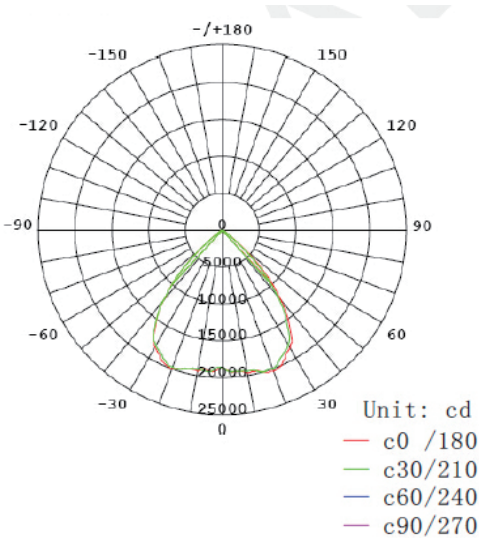

LS-HHBC400W

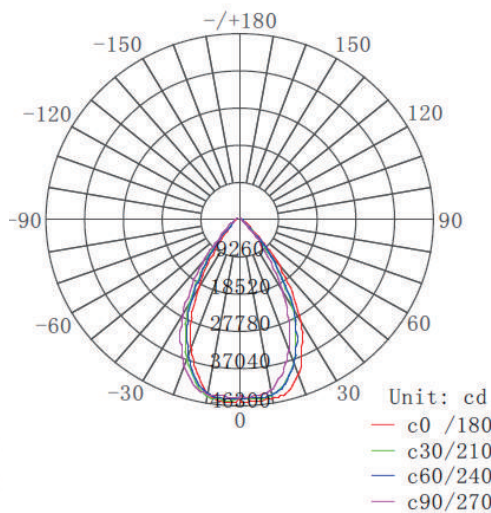

LS-HHBC500W

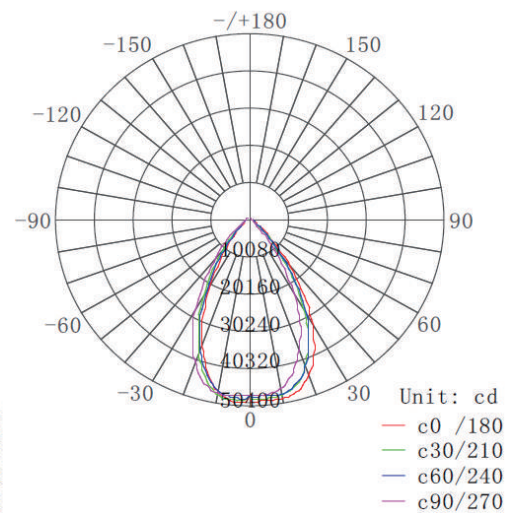

LS-HHBC600W

Main Parameters

| Model# | LS-HHBC400W | LS-HHBC500W | LS-HHBC600W |
|---------------------|-----------------------------------|-------------|-------------|
| Power | 400W | 500W | 600W |
| Output Lumen | 36000lm | 45000lm | 54000lm |
| Certificate | DLC CE RoHS | | |
| Voltage | 90~277VAC (180V-528VAC available) | | |
| LED/Driver brand | CREE XML LED/MEAN WELL Driver | | |
| Material | Die-casting aluminum | | |
| CCT | 3000K-6500K | | |
| Beam Angel | 85Deg.(50%) 105Deg.(10%) | | |
| PF | >0.9 | | |
| CRI | ≥75 | | |
| IP Rating | IP65 Outdoor use | | |
| Working Temperature | -22°F ~140°F/-30°C ~60°C | | |
| Lifespan | >50,000hrs | | |

Applications

LED highbay lights are used in workshops, factories, warehouse, toll stations, gas stations, supermarket, exhibition halls, gymnasiums, etc..

