

**HL-100**  
**LED 8" Flush Heliport**  
**FATO & Aiming Point Light**

Heliport FATO Aiming Point Light is used for night operation. To use omnidirectional white light lighten the heliport aiming point markings/ FATO area. HL-100 flush helipad light proved to be reliable quality and installed at rooftop, surface ground, ships, etc worldwide.

**Applications:**

- Flush mounted FATO edge lights by ICAO standards.
- Aiming point lights
- Flight path alignment lights
- Approach lights

**Compliant:**

- ICAO Annex 14, Volume II, 4th Edition, July, 2013

**Why HL-100:**

- Flush type, lens above the grade only 15mm after installations.
- Fixture can be used with 90V~250V AC, 50Hz or 60Hz.
- Marine treated lamp upper body anodized available.
- Base can is integrated in the light, no need additional purchase cost.
- Ingress protection rating IP68
- Reserved cables at bottom base 1 in-1 out, easy installations.
- Seal components has options for heat or salt-fog environment.

**Optical Characteristics:**

Elevation angle	Azimuth	Light Intensity
30°	-180° to 180°	>10cd
25°	-180° to 180°	>50cd
20°	-180° to 180°	>100cd
10°		
3°	-180° to 180°	>100cd
0°	-180° to 180°	>10cd

**Electrical Characteristics:**

- Power by 90V to 250V AC, or 10V to 30V DC.
- 20 W power consumption.
- White color LED light source 50,000 hours lifetime.
- Dimming of brightness function available with PLUSAFE controller.
- Switchable dual colors is available with PLUSAFE controller.

**Drawings:**

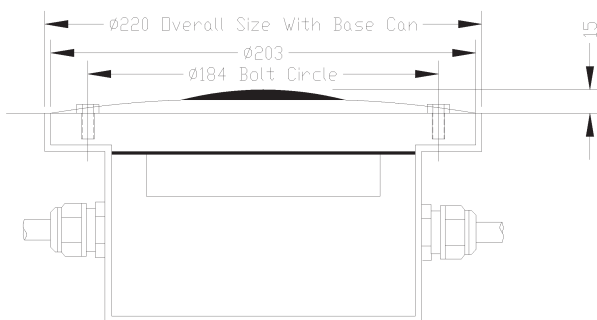

**Physical Characteristics:**

- Die-casting aluminum body and base can.
- All hardwares shall be stainless steel.
- Powder coating finish for body and base can.
- Impact resistant polycarbonate lens cover.
- Sealed by rubber O ring.
- Diameter standard 8"/20.32cm, bolt circle 7.25inch/18.42cm.
- ø22cm external size with base can, 13cm in height.
- 5.5KG net weight.

**Environmental:**

- Operating at -40°C to 60 °C.
- Wind speed: 80m/s.

**Ordering codes:**

Type	Output	Lamp	Treatment
HL-100	W: White B: Blue R: Red G: Green Y: Yellow	AC: 100/250V DC: 10/30V VB: Variable brightness <sup>1</sup> SC: Switchable dual color <sup>2</sup>	MT <sup>3</sup>

<sup>1</sup> Variable brightness, 3 level brightness controlled.

<sup>2</sup> Switchable dual colors, omnidirectional, manual switch to Red/OFF/Green to realize a signal for pilots "Red" close to landing and "Green" available to land.

<sup>3</sup> MT type all hardwares on light shall be A4/316, sealing components like corrosion resistant O-rings, and sealants shall be marine type.

